



LINAK DESKLINE® TROUBLESHOOTING GUIDE

LINAK DESKLINE Troubleshooting

Glossary of Common Terms

- **Components**
 - » **Desk leg (DL)** – The lifting columns, typically with powder coated steel profiles, responsible for lifting the working load of the application.
 - » **Control box (CBD6S)** – Both the computer and power supply of the system.
 - » **Desk panel (DP)** – The user interface. Depending on the model, it is used to activate the application, set memory positions, display the height, display error codes, connect to mobile apps, and give reminders to the user.
 - » **Motor cable** – Transmits low voltage power (18-39 VDC) from the control box to the desk legs, and also transmits PIEZO signals when available from the desk leg.
 - » **Mains cable** – Transmits high voltage power (120 VAC in US and Canada) to the control box.
- **Other**
 - » **Initialize** – Procedure to reset all desk legs to the fully retracted position so that the control box knows where they are.
 - » **Reference** – Any group of desk legs that run in parallel when an Up or Down command is sent to the control box. It is possible to have a custom control box configuration that allows for more than one Reference. [Example: Two (2) desk legs on Reference #1 (Channels #1 and #2) to lift a work surface, and one (1) LA31 on Reference #2 (Channel 3) to adjust a monitor array.]

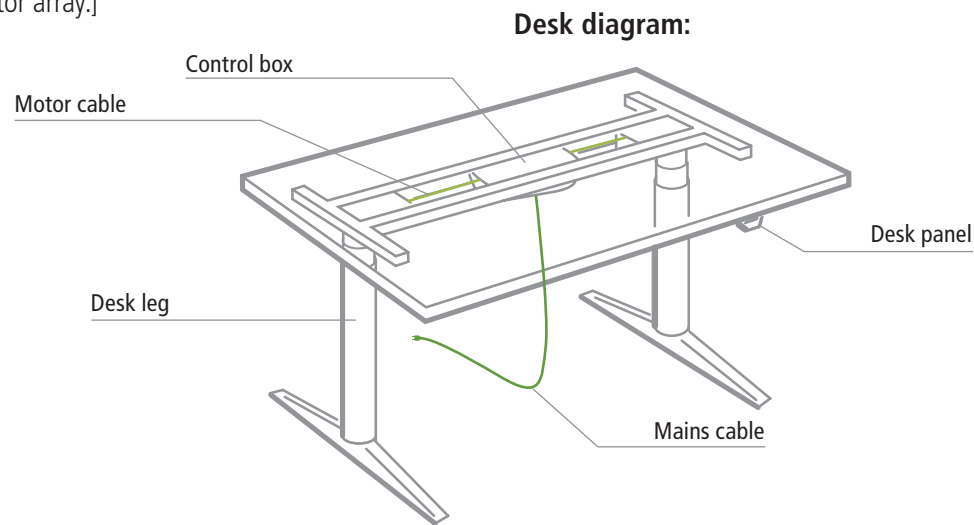

Standard Troubleshooting Procedures

P1 – Initialize the control box (“reset”)

Note: This is commonly the solution when a complaint is that a desk will move down but not up. When a control box requires initialization, this is how the system is programmed to behave.

- STEP 1.** Hold Down button on desk panel to ensure the desk is retracted to its lower limit (whether it’s the fully retracted hard stop, or a configured lower limit).
- STEP 2.** Briefly release Down
- STEP 3.** Press and hold Down for 5 seconds, wait until all desk movement has stopped, then release
 - a. If initialization is successful, you should see a slight up/down “handshake” movement of the desk legs
 - b. If you have a desk panel with display, you should also see E01 during this part of the procedure.

P2 – Check all cable connections

- STEP 1.** Mains cable, connected to both the control box and power outlet.
- STEP 2.** All motor cables, connected to both the control box and desk leg.
 - a. Assuming a standard control box configuration, these must be connected in channels 1 and 2, or channels 1, 2 and 3 for a 3-leg table. They can’t be connected in channels 1 and 3 or 2 and 3 unless there is a configuration on the control box specifying this arrangement.
- STEP 3.** Desk panel cable, connected to the control box in either port A1 or A2 (doesn’t matter which)

P3 – Check for obstructions

STEP 1. Check under, above and on the sides of the desk for any obstructions that could prevent movement in either direction.

Ideally, for each of the following two troubleshooting procedures (P4 and P5), one would have an extra, known good version of the components listed in the Components Glossary at the beginning of this document. It’s not necessary to have the exact same item numbers as those that are being evaluated, unless one is replacing a single desk leg. However, it’s possible to do some troubleshooting with a different type of desk leg.

P4 – Check for faulty component(s) WITH error codes (digital display on Desk Panel, or on app via Bluetooth)

Notes: Check the error code list in the appendix of this troubleshooting guide for assistance. The code should read E##. Some error codes are channel-specific which can help pinpoint the problem.

Symptom	Procedure
System will move down but not up	1. Initialize (P1)
System unresponsive (no power to display with any button is pressed). If any of these steps activates the digital display, initialize the system (P1).	<ol style="list-style-type: none"> 1. Check mains cable connection 2. Test power outlet using another device (lamp, phone charger, etc.) 3. Plug in a new switch and test 4. Connect all existing cables to a new control box and test
System is powered, but will not initialize	<ol style="list-style-type: none"> 1. Try pressing and releasing the down button a few times before pressing and holding for 5 seconds. 2. Also, be aware if the control box has a special configuration: If the desk is programmed with a lower stroke limit, so as to avoid a collision with something like a file cabinet, it is possible that it also has a custom, longer Forced Initialization Time. This is the time required to hold Down before initialization begins. Sometimes this is 10 seconds or longer. 3. If you have a standard control box without a special configuration (i.e. “Plug & Play”), try to initialize each leg in Channel 1 by itself, with nothing else plugged into the motor channels on the control box. Also, swap the motor cables so that a different motor cable is used to initialize Channel 1 by itself. The problem could be a faulty desk leg or a faulty motor cable.
Channel-specific error (Ex: E41 – Channel 1 overload) – <i>Everything except PIEZO errors (E59-E63)</i>	<ol style="list-style-type: none"> 1. Swap the motor cable connections at the control box (Motor cable #1 from channel 1 to 2, motor cable #2 from channel 2 to 1). If it remains E41, there could be a problem with the application (load or obstruction on one side) or a bad control box. If the error changes to E42, go to step P4-3-b. 2. Swap the motor cable connections at the desk legs, so that the leg that was originally connected to Channel 1 is back in Channel 1, but with the motor cable that was originally connected to Channel 2. If it remains E42, it is most likely a bad motor cable, now connected to Channel 2. If it goes back to E41, it is most likely a bad desk leg, now connected to Channel 1.

Symptom	Procedure
Desk is uneven	<ol style="list-style-type: none"> 1. Initialize the desk. If both legs begin to run down, complete the initialization. If only one leg moves, stop and move to Step 2. 2. Check motor cable connections. Check to ensure motor cables are not pulled during movement. With a standard, Plug & Play control box, it's possible that only one leg is connected, and connected to Channel 1. In this case, it will initialize and run Channel 1 only. If there is only one leg but it's connected to Channel 2, it will not initialize. 3. If a motor cable was disconnected, try initializing again. 4. If unsuccessful, connect the desk leg from Channel 2 into Channel 1, with nothing in Channel 2, and initialize. 5. Try initializing the same leg that's in Channel 1, but with a different motor cable. If it still won't initialize, replace the desk leg.

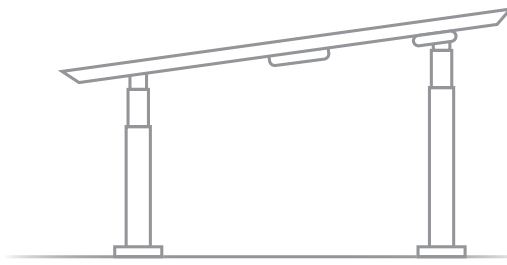

P5 – Check for faulty component WITHOUT error codes (no digital display on Desk Panel, no Bluetooth)

Symptom	Procedure
System will move down but not up	<ol style="list-style-type: none"> 1. Initialize (P1)
System will not initialize. OR System won't complete the full range of motion.	<ol style="list-style-type: none"> 1. Check mains cable connection. Test power outlet using another device (lamp, phone charger, etc.) 2. Plug in a new switch.
– After each of these steps, attempt to initialize (P1).	<ol style="list-style-type: none"> 3. Connect all existing cables to a new control box. 4. Try pressing and releasing the down button a few times before pressing and holding for 5 seconds. 5. Also, be aware if the control box has a special configuration: If the desk is programmed with a lower stroke limit, so as to avoid a collision with something like a file cabinet, it is possible that it also has a custom, longer Forced Initialization Time. This is the time required to hold Down before initialization begins. Sometimes this is 10 seconds or longer. 6. If you have a standard control box without a special configuration (i.e. "Plug & Play"), try to initialize each leg in Channel 1 by itself, with nothing else plugged into the motor channels on the control box. Also, swap the motor cables so that a different motor cable is used to initialize Channel 1 by itself. The problem could be a faulty desk leg or a faulty motor cable.
Desk is uneven	<ol style="list-style-type: none"> 1. Desk is uneven (P4)

Appendix

What is the Control Box Thinking?

There are many clever procedures, checks and measurements performed in the control box. Here is a brief description of what the control box is trying to accomplish while it is activating an application:

- **Safe activation of the application**
 - o Parallel, even movement of all desk legs in the application is critical.
 - » The control box does not directly know the position of each desk leg. Instead, the position of each leg is constantly calculated via Hall pulses from each motor. The legs on a single reference are not allowed to be more than +/- 5 Hall pulses out of sync. For a standard DL, this amounts to +/- 0.55 mm.
 - » Motor cable disconnections are also detected as errors.
 - o If PIEZO technology is present in the desk leg, the control box monitors for PIEZO "collision" signals from each channel. When a PIEZO signal is sensed, movement is immediately stopped and, if there is room, the system is ran in the opposite direction a small distance.
 - o Anytime the control sees an incomplete signal, or more than one signal (multiple keys pressed, multiple desk panels activated at the same time), an error is determined and no movement is allowed at that moment. This is to prevent an action of movement that is not intended by the user.
- **Protection from equipment damage**
 - o Internal temperature of the control box is monitored.
 - o Maximum current draw for each motor channel, as well as the system as a whole, is measured. When the current exceeds an allowable limit, an error is presented.

Error codes

ERROR CODE	NAME	DESCRIPTION	POTENTIAL CAUSE	TROUBLESHOOTING
E01	Position Lost	The desk has an unknown position and needs to be initialized	» Position error » New Desk Leg added	• Initialize the system
E02	General Overload Up	Overload in upward direction has occurred	» Obstruction » Bad leg or motor cable	• Check all cable connections, initialize the system • Troubleshoot components by initializing 1 at a time (only possible with Plug & Play configuration)
E03	General Overload Down	Overload in downward direction has occurred	» Obstruction » Bad leg or motor cable	• Check all cable connections, initialize the system • Troubleshoot components by initializing 1 at a time (only possible with Plug & Play configuration)
E08	Watchdog	Indicate that software failed to kick watchdog	» Program fault	• Unplug mains cable for 15 sec • Initialize the system • Replace Control Box
E09	LIN collision	Collisions detected on the LIN bus	» Key pressed on two or more connected handset simultaneously » Multiple LINBUS devices activated	• Check if another desk panel is connected and being activated • Unplug all but one desk panel and test system
E10	Power fail	Power fail happened, or power regulator adjusted below 10%	» Mains cable pulled during driving » Internal fault » Only 1 battery for a 3- or 4-channel system » "E10 is a power fail, voltage on power supply drops below a certain limit, power removed"	• Check mains cable is not caught, and is allowed to freely travel • Use strain-relief loop built into control box • Use a 2nd battery; charge batteries
E11	Channel mismatch	Change in number of actuators since initialization	» Disconnection » Desk Leg added	• Check Motor cable connections and Integrity • Change Motor cable or Desk Leg • Initialize the system
E12	Position error	One channel have position different than others	» Too much back drive occurred	• Move table to fully retracted position • Initialize system
E13	Short circuit	Short circuit detected during operation	» Squeezed Motor Cable » Short in motor	• Check motor cable connections • Isolate and replace Motor Cable • Isolate and replace Desk Leg

ERROR CODE	NAME	DESCRIPTION	POTENTIAL CAUSE	TROUBLESHOOTING
E15	Power limit	System has reached its power limitation	» Mains cable pulled during driving » Internal fault » Many times will see this alongside E10 » "E15 is when power regulator has adjusted speed down on actuators without any significant current draw, usually caused by power supply dropping."	• Check mains cable is not caught, and is allowed to freely travel • Use strain-relief loop built into control box
E16	Key Error	Illegal keys pressed (handled internally in DP1C).	» Hitting multiple buttons simultaneously	• Check switch
E17	Safety missing	LIN bus unit does not support safety feature	» DP1C/DPF1C does not have up-to-date software	• Try DP with more recent software version (version printed on label)
E18	Missing Initialization plug	A special service tool is required to change number of channels to the system	[BASELIFT Only] » Service tool missing from BASELIFT system when initializing	• Add service tool
E23	Ch1 missing	Channel 1 is detected missing	» Disconnection » Faulty motor cable » Faulty motor in leg	• Check Motor cable connections and Integrity • Change Motor cable or Desk Leg • Initialize the system
E24	Ch2 missing	Channel 2 is detected missing	» Disconnection » Faulty motor cable » Faulty motor in leg	• Check Motor cable connections and Integrity • Change Motor cable or Desk Leg • Initialize the system
E25	Ch3 missing	Channel 3 is detected missing	» Disconnection » Faulty motor cable » Faulty motor in leg	• Check Motor cable connections and Integrity • Change Motor cable or Desk Leg • Initialize the system
E26	Ch4 missing	Channel 4 is detected missing	» Disconnection » Faulty motor cable » Faulty motor in leg	• Check Motor cable connections and Integrity • Change Motor cable or Desk Leg • Initialize the system

ERROR CODE	NAME	DESCRIPTION	POTENTIAL CAUSE	TROUBLESHOOTING
E29	Ch1 type	Channel 1 is not same type as when initialized	» Change in Desk Leg type » Loose wire inside motor	• Check Desk Leg type • Change Desk Leg • Initialize the system
E30	Ch2 type	Channel 2 is not same type as when initialized or not same type as channel 1	» Change in Desk Leg type » Loose wire inside motor	• Check Desk Leg type • Change Desk Leg • Initialize the system
E31	Ch3 type	Channel 3 is not same type as when initialized or not same type as channel 1	» Change in Desk Leg type » Loose wire inside motor	• Check Desk Leg type • Change Desk Leg • Initialize the system
E32	Ch4 type	Channel 4 is not same type as when initialized or not same type as channel 1	» Change in Desk Leg type » Loose wire inside motor	• Check Desk Leg type • Change Desk Leg • Initialize the system
E35	Ch1 pulse fail	Channel 1 had to many pulse errors	» Loose/faulty cable » Hall sensor PCB	• Check motor cable connections and integrity • Initialize the system • Change Desk Leg
E36	Ch2 pulse fail	Channel 2 had to many pulse errors	» Loose/faulty cable » Hall sensor PCB	• Check motor cable connections and integrity • Initialize the system • Change Desk Leg
E37	Ch3 pulse fail	Channel 3 had to many pulse errors	» Loose/faulty cable » Hall sensor PCB	• Check motor cable connections and integrity • Initialize the system • Change Desk Leg
E38	Ch4 pulse fail	Channel 4 had too many pulse errors	» Loose/faulty cable » Hall sensor PCB	• Check motor cable connections and integrity • Initialize the system • Change Desk Leg
E41	Ch1 overload up	Overload up occurred on channel 1	» Leg is overloaded » Hit obstruction » Reached end stop (before initialization at upper end-stop occurs)	• Remove obstruction • Remove load • Initialize if necessary
E42	Ch2 overload up	Overload up occurred on channel 2	» Leg is overloaded » Hit obstruction » Reached end stop (before initialization at upper end-stop occurs)	• Remove obstruction • Remove load • Initialize if necessary

ERROR CODE	NAME	DESCRIPTION	POTENTIAL CAUSE	TROUBLESHOOTING
E43	Ch3 overload up	Overload up occurred on channel 3	» Leg is overloaded » Hit obstruction » Reached end stop (before initialization at upper end-stop occurs)	• Remove obstruction • Remove load • Initialize if necessary
E44	Ch4 overload up	Overload up occurred on channel 4	» Leg is overloaded » Hit obstruction » Reached end stop (before initialization at upper end-stop occurs)	• Remove obstruction • Remove load • Initialize if necessary
E47	Ch1 overload down	Overload down occurred on channel 1	» Hit obstruction	• Remove obstruction • Initialize if necessary
E48	Ch2 overload down	Overload down occurred on channel 2	» Hit obstruction	• Remove obstruction • Initialize if necessary
E29	Ch1 type	Channel 1 is not same type as when initialized	» Change in Desk Leg type » Loose wire inside motor	• Check Desk Leg type • Change Desk Leg • Initialize the system
E30	Ch2 type	Channel 2 is not same type as when initialized or not same type as channel 1	» Change in Desk Leg type » Loose wire inside motor	• Check Desk Leg type • Change Desk Leg • Initialize the system
E31	Ch3 type	Channel 3 is not same type as when initialized or not same type as channel 1	» Change in Desk Leg type » Loose wire inside motor	• Check Desk Leg type • Change Desk Leg • Initialize the system
E32	Ch4 type	Channel 4 is not same type as when initialized or not same type as channel 1	» Change in Desk Leg type » Loose wire inside motor	• Check Desk Leg type • Change Desk Leg • Initialize the system
E35	Ch1 pulse fail	Channel 1 had to many pulse errors	» Loose/faulty cable » Hall sensor PCB	• Check motor cable connections and integrity • Initialize the system • Change Desk Leg
E36	Ch2 pulse fail	Channel 2 had to many pulse errors	» Loose/faulty cable » Hall sensor PCB	• Check motor cable connections and integrity • Initialize the system • Change Desk Leg
E37	Ch3 pulse fail	Channel 3 had to many pulse errors	» Loose/faulty cable » Hall sensor PCB	• Check motor cable connections and integrity • Initialize the system • Change Desk Leg

ERROR CODE	NAME	DESCRIPTION	POTENTIAL CAUSE	TROUBLESHOOTING
E38	Ch4 pulse fail	Channel 4 had too many pulse errors	» Loose/faulty cable » Hall sensor PCB	<ul style="list-style-type: none"> • Check motor cable connections and integrity • Initialize the system • Change Desk Leg
E41	Ch1 overload up	Overload up occurred on channel 1	» Leg is overloaded » Hit obstruction » Reached end stop (before initialization at upper end-stop occurs)	<ul style="list-style-type: none"> • Remove obstruction • Remove load • Initialize if necessary
E42	Ch2 overload up	Overload up occurred on channel 2	» Leg is overloaded » Hit obstruction » Reached end stop (before initialization at upper end-stop occurs)	<ul style="list-style-type: none"> • Remove obstruction • Remove load • Initialize if necessary
E43	Ch3 overload up	Overload up occurred on channel 3	» Leg is overloaded » Hit obstruction » Reached end stop (before initialization at upper end-stop occurs)	<ul style="list-style-type: none"> • Remove obstruction • Remove load • Initialize if necessary
E44	Ch4 overload up	Overload up occurred on channel 4	» Leg is overloaded » Hit obstruction » Reached end stop (before initialization at upper end-stop occurs)	<ul style="list-style-type: none"> • Remove obstruction • Remove load • Initialize if necessary
E47	Ch1 overload down	Overload down occurred on channel 1	» Hit obstruction	<ul style="list-style-type: none"> • Remove obstruction • Initialize if necessary
E48	Ch2 overload down	Overload down occurred on channel 2	» Hit obstruction	<ul style="list-style-type: none"> • Remove obstruction • Initialize if necessary
E49	Ch3 overload down	Overload down occurred on channel 3	» Hit obstruction	<ul style="list-style-type: none"> • Remove obstruction • Initialize if necessary
E50	Ch4 overload down	Overload down occurred on channel 4	» Hit obstruction	<ul style="list-style-type: none"> • Remove obstruction • Initialize if necessary
E53	Ch1 anti-col	Anti-collision triggered on channel 1	» Hit Obstruction	<ul style="list-style-type: none"> • Remove obstruction • Initialize if necessary
E54	Ch2 anti-col	Anti-collision triggered on channel 2	» Hit Obstruction	<ul style="list-style-type: none"> • Remove obstruction • Initialize if necessary
E55	Ch3 anti-col	Anti-collision triggered on channel 3	» Hit Obstruction	<ul style="list-style-type: none"> • Remove obstruction • Initialize if necessary

ERROR CODE	NAME	DESCRIPTION	POTENTIAL CAUSE	TROUBLESHOOTING
E56	Ch4 anti-col	Anti-collision triggered on channel 4	» Hit Obstruction	<ul style="list-style-type: none"> • Remove obstruction • Initialize if necessary
E59	Ch1 SLS/PIEZO	Safety limit switch activated on channel 1	» Hit Obstruction	<ul style="list-style-type: none"> • Remove obstruction • Initialize if necessary
E60	Ch2 SLS/PIEZO	Safety limit switch activated on channel 2	» Hit Obstruction	<ul style="list-style-type: none"> • Remove obstruction • Initialize if necessary
E61	Ch3 SLS/PIEZO	Safety limit switch activated on channel 3	» Hit Obstruction	<ul style="list-style-type: none"> • Remove obstruction • Initialize if necessary
E62	Ch4 SLS/PIEZO	Safety limit switch activated on channel 4	» Hit Obstruction	<ul style="list-style-type: none"> • Remove obstruction • Initialize if necessary
E65	Ch1 pulse dir	Pulses counted wrong direction in channel 1	» Motor poles are crossed » Hall sensor Cables are crossed	<ul style="list-style-type: none"> • Check motor cable connections and integrity • Initialize the system • Exchange Desk Leg
E66	Ch2 pulse dir	Pulses counted wrong direction in channel 2	» Motor poles are crossed » Hall sensor Cables are crossed	<ul style="list-style-type: none"> • Check motor cable connections and integrity • Initialize the system • Exchange Desk Leg
E67	Ch3 pulse dir	Pulses counted wrong direction in channel 3	» Motor poles are crossed » Hall sensor Cables are crossed	<ul style="list-style-type: none"> • Check motor cable connections and integrity • Initialize the system
E68	Ch4 pulse dir	Pulses counted wrong direction in channel 4	» Motor poles are crossed » Hall sensor Cables are crossed	<ul style="list-style-type: none"> • Check motor cable connections and integrity • Initialize the system
E71	Ch1A short	Short circuit on channel 1 [If T-splitter is used, short circuit on 1A]	» Damage to motor cable » Damage to cable exiting leg (if applicable)	<ul style="list-style-type: none"> • Inspect motor cable for damage, replace if damaged • Inspect cable exiting leg (if applicable), replace if damaged.
E72	Ch1B short	Short circuit on channel 1 [If T-splitter is used, short circuit on 1B]	» Damage to motor cable » Damage to cable exiting leg (if applicable)	<ul style="list-style-type: none"> • Inspect motor cable for damage, replace if damaged • Inspect cable exiting leg (if applicable), replace if damaged.
E73	Ch2A short	Short circuit on channel 2 [If T-splitter is used, short circuit on 2A]	» Damage to motor cable » Damage to cable exiting leg (if applicable)	<ul style="list-style-type: none"> • Inspect motor cable for damage, replace if damaged • Inspect cable exiting leg (if applicable), replace if damaged.
E74	Ch2B short	Short circuit on channel 2 [If T-splitter is used, short circuit on 2B]	» Damage to motor cable » Damage to cable exiting leg (if applicable)	<ul style="list-style-type: none"> • Inspect motor cable for damage, replace if damaged • Inspect cable exiting leg (if applicable), replace if damaged.



GLOBAL PRESENCE

LINAK has a well-developed sales and service organization in Europe, Americas, Asia and Australia. Therefore, we can assist you and your customers locally, under the global sales concept idea:

Be global, act local.

LINAK has a world-class sales and service organisation.
Today we are present in 35 countries all over the world.
For further information, please visit our website: www.linak-us.com

LINAK® 
WE IMPROVE YOUR LIFE